

FCC STATEMENT

This device complies with Part 15 of the FCC Rules. Operation is subject to the following two conditions:

- (1) This device may not cause harmful interference, and
- (2) This device must accept any interference received, including interference that may cause undesired operation.

Note:

This equipment has been tested and found to comply with the limits for Class B digital devices, pursuant to Part 15 of the FCC rules. These limits are designed to provide reasonable protection against harmful interference in a residential installation. This equipment generates uses and can radiate radio frequency energy and, if not installed and used in accordance with the instructions, may cause harmful interference to radio communications. However, there is no guarantee that interference will not occur in a particular installation. If this equipment does cause harmful interference to radio or television reception, which can be determined by turning the equipment off and on, the user is encouraged to try to correct the interference by one or more of the following measures:

- Reorient or relocate the receiving antenna.
- Increase the separation between the equipment and receiver.
- Connect the equipment into an outlet on a circuit different from that to which the receiver is connected.
- Consult the dealer or an experienced radio/TV technician for help.

Use of shielded cable is required to comply with Class B limits in Subpart B of Part 15 of the FCC rules. Do not make any changes or modifications to the equipment unless otherwise specified in the manual. If such changes or modifications should be made, you could be required to stop operation of the equipment.

TRADEMARK INFORMATION

- Microsoft® and Windows® are U.S. registered trademarks of Microsoft Corporation.
- Pentium® is a registered trademark of Intel Corporation.
- Macintosh is a trademark of Apple Computer, Inc.
- SD™ is a trademark.
- Other names and products may be trademarks or registered trademarks of their respective owners.

READ THIS FIRST

Notice:

- Product design and specifications are subject to change without notice. This includes primary product specifications, software, software drivers, and user's manual. This User Manual is a general reference guide for the product.
- The illustrations in this manual are for the purpose of explanation and may differ from the actual design of your camera.
- The manufacturer assumes no liability for any errors or discrepancies in this user manual.
- For driver updates, refer to our website.

Safety Instructions

Read and understand all **Warnings** and **Cautions** before using this product.

WARNING

If foreign objects or water have entered the camera, turn the power OFF and remove the battery and the AC power adapter.

Continued use in this state might cause fire or electric shock. Consult the store of purchase.



If the camera has fallen or its case has been damaged, turn the power OFF and remove the battery and the AC power adapter.

Continued use in this state might cause fire or electric shock. Consult the store of purchase.



Do not disassemble, change or repair the camera.

This might cause fire or electric shock. For repair or internal inspection, ask the store of purchase.



Use the supplied AC power adapter only with the indicated power supply voltage.

Use with any other power supply voltage might cause fire or electric shock.



CAUTION**Insert the battery paying careful attention to the polarity (+ or -) of the terminals.**

Inserting the battery with its polarities inverted might cause fire and injury, or damage to the surrounding areas due to the battery rupturing or leaking.

**Do not fire the flash close to anyone's eyes.**

This might cause damage to the person's eyesight.

**Do not subject the LCD monitor to impact.**

This might damage the glass on the screen or cause the internal fluid to leak. If the internal fluid enters your eyes or comes into contact with your body or clothes, rinse with fresh water. If the internal fluid has entered your eyes, consult a physician to receive treatment.

**A camera is a precision instrument. Do not drop it, strike it or use excessive force when handling the camera.**

This might cause damage to the camera.

**Do not use the camera in humid, steamy, smoky, or dusty places.**

This might cause fire or electric shock.

**Do not remove the battery immediately after long period of continuous use.**

The battery becomes hot during use. Touching a hot battery might cause burns.

**Do not wrap the camera or place it in cloth or blankets.**

This might cause heat to build up and deform the case, resulting in fire. Use the camera in a well-ventilated place.

**Do not leave the camera in places where the temperature may rise significantly, such as inside a car.**

This might adversely affect the case or the parts inside, resulting in fire.

**Before you move the camera, disconnect cords and cables.**

Failure to do this might damage cords and cables, resulting in fire and electric shock.



Notes on Battery Usage

When you use the battery, carefully read and strictly observe the **Safety Instructions** and the notes described below:

- Use only the specified battery (1050mAh, 3.7V).
- Avoid using battery in extremely cold environments as low temperatures can shorten the battery life and reduce camera performance.
- When you are using the new rechargeable battery or rechargeable battery that has not been used for an extended period of time (the battery that passed the expiry date is an exception) might affect the number of images that can be captured. Therefore, to maximize its performance and lifetime, we recommend that you fully charge the battery and discharge it for at least one complete cycle before use.
- The battery may feel warm after long period of continuous use of the camera or the flash. This is normal and not a malfunction.
- The camera may feel warm after long period of continuous use. This is normal and not a malfunction.
- If the battery is not to be used for a long period of time, remove it from the camera to prevent leakage or corrosion.
- If the battery is not to be used for a long period of time, store it after no battery power left. If the battery is stored for a long time in a fully charged state, its performance may be impaired.
- Always keep the battery terminals in a clean state.
- Risk of explosion if battery is replaced by an incorrect type.
- Dispose of used batteries according to the instructions.

CONTENTS

8 INTRODUCTION

- 8 Overview
- 10 Package Contents

11 GETTING TO KNOW THE CAMERA

- 11 Front View
- 12 Rear View
- 14 Mode dial
- 15 Status LED Indicator
- 16 LCD Monitor Icons

19 GETTING STARTED

- 19 Attaching the Camera Strap
- 20 Inserting and Removing the Battery
- 21 Charging the Battery
- 22 Using an AC Power Adapter
- 22 Inserting and Removing an SD Card (Optional Accessory)
- 23 Turning the Power On/Off
- 24 Setting the Date and Time
- 25 Choosing the Display Language
- 26 Formatting an SD Memory Card
- 27 Setting Image Resolution and Quality

29 PHOTOGRAPHY MODE

- 29 **[A]** Auto Mode
- 31 Using the Optical Zoom
- 32 Using the Digital Zoom
- 33 Setting the Flash
- 35 Setting the Focus
- 36 Setting the Self-timer
- 37 Exposure Compensation/Backlight Correction
- 38 **[P]** Program (Automatic Exposure) Photography Mode
- 39 **[Tv]** Shutter Speed Priority Photography Mode
- 40 **[Av]** Aperture Priority Mode
- 41 **[M]** Manual Mode
- 42 Setting the Scene Mode
- 43 **[M]** Movie Mode

44 PLAYBACK MODE

- 44 Playing Back Still Images
- 45 Playing Back Video Clips
- 46 Playing Back Still Images/Video Clips on a TV
- 47 Attaching Voice Memos
- 48 Thumbnail Display
- 49 Zoom Playback
- 50 Slideshow Display
- 51 Protecting Images
- 53 [] Deleting Images
- 55 DPOF Settings

57 MENU OPTIONS

- 57 Photography Menu (Picture tab)
- 59 Photography Menu (Function tab)
- 61 Photography Menu (AE/AWB tab)
- 63 Playback Menu
- 64 Setup Menu (Basic tab)
- 66 Setup Menu (Custom tab)

67 TRANSFERRING RECORDED IMAGES AND VIDEOS TO YOUR COMPUTER

- 68 Step 1: Installing the USB Driver
- 69 Step 2: Connecting the Camera to Your Computer
- 70 Step 3: Downloading Images and Video Files

71 CONNECTING THE CAMERA DIRECTLY TO THE PRINTER FOR PRINTING IMAGES (PICTBRIDGE FUNCTION)**73 INSTALLING PHOTO EXPLORER****74 INSTALLING PHOTO EXPRESS****75 CONNECTING THE CAMERA TO OTHER DEVICES****76 CAMERA SPECIFICATIONS****78 TROUBLESHOOTING**

INTRODUCTION

Overview

Congratulations on your purchase of the new digital camera. Capturing high-quality digital images is fast and easy with this state-of-the-art smart camera. Equipped with a 8.1 Mega pixels CCD, this camera is capable of capturing images with a resolution of up to 3264 x 2448 pixels.

Other cool features provided by the camera include the following:

LCD monitor -	2.5" LTPS TFT color LCD monitor makes it easy to frame your subject when capturing images. It also displays the images you have captured.
Optical zoom -	The 3x optical lens allows you to capture telephoto and wide-angle images.
Digital zoom -	5.1x digital zoom in conjunction with the 3x optical zoom permit zoom photography of up to 15.3 times. Captured images may be reviewed and a selected portion of an image may be enlarged up to 4x.
Flexible flash settings -	You may adjust the flash setting according to your lighting environment.
Focus mode -	Images can be captured with the distance to the subject set by auto focus, macro or infinity.
Self-timer mode -	The self-timer may set to 10 seconds, 2 seconds or 10+2 seconds.
Capture mode -	You may capture different images including single, a series of 3 images using auto-exposure bracketing, and 3 images continuously.
Movie mode -	In addition to still-images, you may capture video clips with audio (voice).
Voice memo -	You may annotate your images with a 30 second voice memo. Images may be voice-annotated at the time of capture, or during playback.
Thumbnail display -	Display your images in sets of nine on the LCD monitor for quick selection of an particular image.

Recording media -	The camera uses Secure Digital (SD) memory cards up to 1GB.
TV and PC connection -	You may view your images on a television monitor or a computer using the USB or A/V cables.
DPOF support -	You may print your images on a DPOF compatible printer by simply inserting the memory card with embedded printing information.
PictBridge support-	You may connect the camera directly to a PictBridge compatible printer and perform image selection and printing using the camera monitor screen and controls.

Package Contents

Carefully unpack your kit box and ensure that you have the following items:

- Digital Camera
- A/V cable
- USB cable
- User's manual
- Software CD-ROM
- Camera strap
- AC power adapter
- Rechargeable lithium-ion battery
- Warranty card

GETTING TO KNOW THE CAMERA

Front View

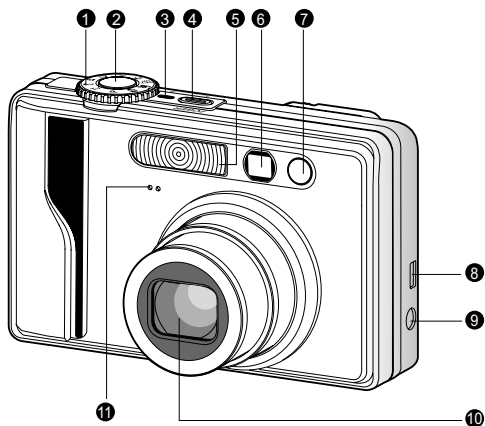

#	Name	Description
1	Mode dial	Sets the camera mode
2	Shutter button	Focuses and locks both focus & exposure when pressed halfway down. Captures the image when pressed all the way down.
3	Power indicator	Lights on when the camera power is turned on.
4	POWER (Power) button	Turns the camera power on and off.
5	Flash	Provides flash illumination.
6	Viewfinder window	Allows you to frame the subject of the image.
7	Self-timer LED (AF auxiliary light)	Blinks green during Self-timer mode until the image is captured.
8	USB or A/V OUT terminal	Allows you to connect a USB cable or an A/V cable to the camera.
9	DC IN 5V terminal	Allows you to connect an AC power adapter to operate the camera without battery, or to charge rechargeable lithium-ion battery.
10	Lens	3x optical zoom lens allows you to capture telephoto and wide-angle images.
11	Microphone	For recording audio with video clips and voice annotation.

Rear View

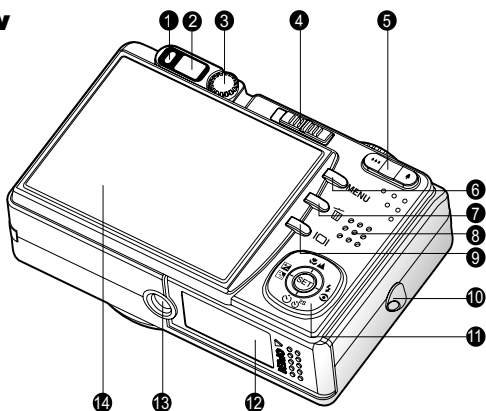

#	Name	Description
1	Status LED	Indicates the cameras operational status.
2	Viewfinder window	Allows you to compose your subject using the optical viewfinder.
3	Diopter adjustment dial	Provides a clearer image when using the optical viewfinder.
4	Mode switch 📷 Photography mode	Sets the camera mode. Selects this when capturing still images or recording video clips.
	▶ Playback mode	Performs image playback and deletion.
5	⬆ (Zoom in) button	Zooms the lens to telephoto position.
	⬇ (Zoom out) button	Zooms the lens to wide-angle position.
6	MENU (Menu) button	Toggles On-Screen Display (OSD) menu on and off.
7	🗑 (Delete) button	Allows you to delete an image.
8	Speaker	For playback or recorded audio.
9	📺 (Display) button	Turns the LCD monitor display and live view on and off.
10	Strap holder	Camera strap attachment.
11	Multi-selector button	Allows you to scroll through menus and images, and then select your choices.
12	Battery/SD card cover	Access to the battery and memory card.
13	Tripod socket	For tripod mounting.
14	LCD monitor	For image preview/review. Displays control menus, camera settings, and operational icons.



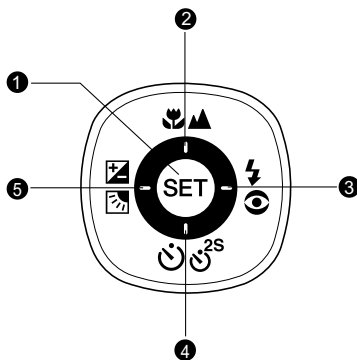

Multi-selector button

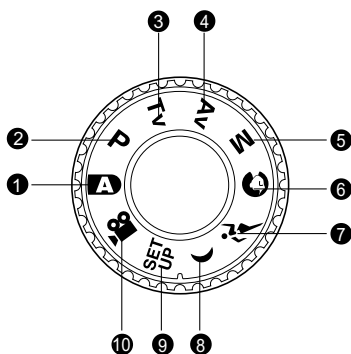

#	Name	Description
1	SET button	Enters the menu page and confirms the chosen setting.
2	▲ button ▲▲ (Focus) button	Scrolls upwards. Allows you to choose the appropriate focus setting.
3	▶ button ⚡ (Flash) button	Scrolls right. Allows you to choose the appropriate flash setting.
4	▼ button ⌚ ^{2S} (Self-timer) button	Scrolls downwards. Allows you to toggle the self-timer on and off, selects the desired self-timer mode.
5	◀ button ☒ (Exposure compensation/ Backlight correction) button	Scrolls left. Allows you to toggle the exposure compensation/ backlight correction on and off.

Mode dial



#	Mode	Description
1	A Auto photography	The camera automatically sets for exposure, etc.
2	P Program (auto exposure)	In program mode the shutter speed and aperture will be set automatically, but other parameters may be set manually.
3	Tv Shutter speed priority	You may specify the shutter speed while the camera sets the corresponding aperture value.
4	Av Aperture priority	You may specify the aperture value while the camera sets the corresponding shutter speed.
5	M Manual photography	For full manual control over exposure, aperture and other settings.
6	 Portrait	To photograph a person and defocus (blur) the background.
7	 Sports	For photographing fast-moving subjects.
8	 Night scene	For photographing evening or night scenes.
9	 Set-up	Specify your camera's settings.
10	 Movie	For recording video clips.

Status LED Indicator

The status LED indicates the current operational status of the camera. The meaning of the LED changes depending upon what the camera is doing.

Color	State	During power off	During photography	During connection to a PC
Green	On	The completion of battery charge.	AE or AF is locked with the shutter button held halfway.	-
	Flashing	The battery is charging.	-	-
Red	On	Battery charging error.	Image is being processed and stored to SD card.	In communication to PC. (SD card is inserted.)
	Flashing	-	When the image is not in focus.	-
Orange	On	-	Flash charging in progress.	-
	Flashing	-	Hardware malfunction.	SD card is not inserted.

LCD Monitor Icons

For Photography modes: [A] [O] [Z] [C]

1. Mode icon
2. Zoom status
3. Voice memo
4. Battery condition
 [Full battery power]
 [Medium battery power]
 [Low battery power]
 [Virtually no battery power]
5. Flash mode
 [Blank] Automatic
 [Red-eye Reduction]
 [Forced Flash]
 [Flash Off]
6. Main focus area
7. Capture mode icon
 [Blank] Single
 [Continuous]
 [AEB] Auto Exp.
8. Image resolution
 [3264 x 2448]
 [2560 x 1920]
 [1600 x 1200]
 [640 x 480]
9. Available number of shots

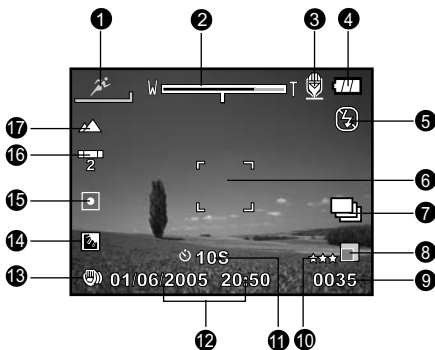

10. Image quality
 [★★★] Fine
 [★★] Standard
 [★] Economy
 [TIFF] TIFF
11. Self-timer icon
 [10S] 10 sec.
 [2S] 2 sec.
 [10+2] 10+2 sec.
12. Date and time
13. Long-exposure time warning icon (potential for hand-shake blur)
14. Backlight correction
15. Metering
 [Multi]
 [Spot]
16. White balance
 [Blank] Auto
 [Incandescent]
 [Fluorescent 1]
 [Fluorescent 2]
 [Day Light]
 [Cloudy]
 [Manual]
17. Focus setting
 [Blank] Auto focus
 [Macro]
 [Infinity]



NOTE

- Pressing the [O] button changes the LCD display in the sequence of: display with icons, display without icons, LCD monitor OFF.

For Photography modes: [P] [Tv] [Av] [M]

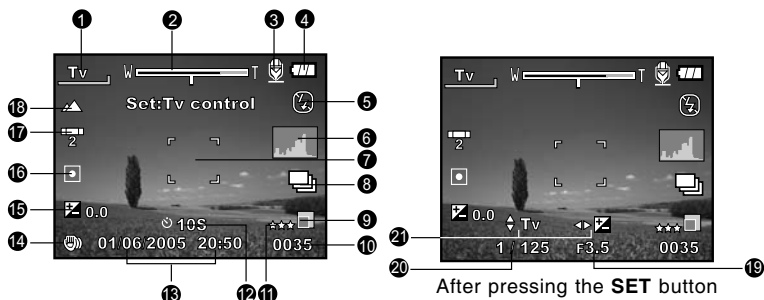

- | | |
|-------------------------------|--|
| 1. Mode icon | 13. Date and time |
| 2. Zoom status | 14. Long-exposure time warning icon
(potential for hand-shake blur) |
| 3. Voice memo | 15. [] Exposure compensation
[] Backlight correction |
| 4. Battery condition | 16. Metering |
| 5. Flash mode | 17. White balance |
| 6. Histogram | 18. Focus setting |
| 7. Main focus area | 19. Aperture |
| 8. Capture mode icon | 20. Shutter speed |
| 9. Image resolution | 21. Shutter speed/Aperture/EV control
indicators |
| 10. Available number of shots | |
| 11. Image quality | |
| 12. Self-timer icon | |



NOTE

- Pressing the [] button changes the LCD display in the sequence of: display with icons, display with icons and histogram, display without icons, LCD monitor OFF.

For Movie mode []

1. Mode icon
2. Zoom status
3. Battery condition
4. Video resolution
5. Available recording time/Elapsed time
6. Video quality
7. Self-timer icon
8. Date and time
9. Focus setting

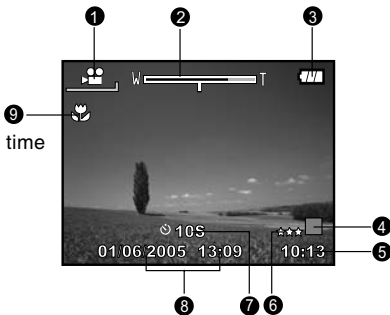

Playback mode [] -Still image playback

1. Mode icon
2. File number
3. Folder number
4. Protect icon
5. Voice memo
6. DPOF icon

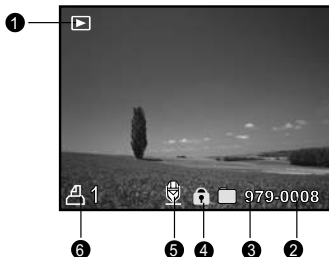

Playback mode []-Video playback

1. Video status bar
2. Elapsed time
3. File number
4. Folder number
5. Protect icon
6. Mode icon
7. Play mode
8. Sound off icon (When the [▲] button is pressed during video playback.)
9. Total time

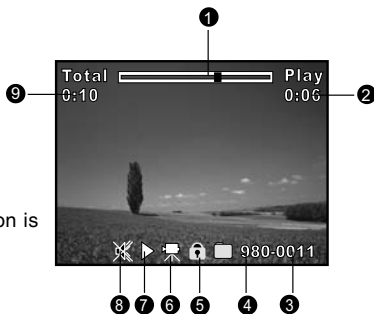

GETTING STARTED

Attaching the Camera Strap

Attach the camera strap as shown in the illustration.

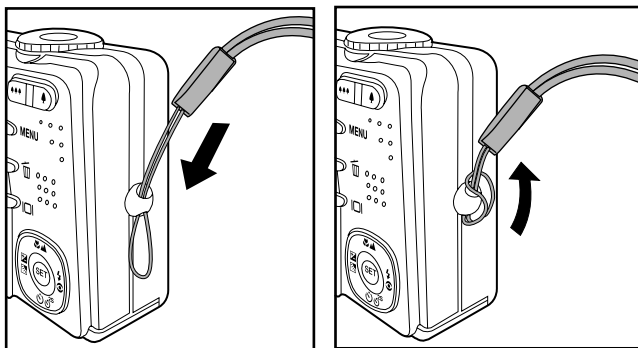

Inserting and Removing the Battery

We highly recommend using specified rechargeable lithium-ion battery (1050mAh, 3.7V) to realize the full capability of your camera. Charge the battery fully before using the camera. Make sure that the power of the camera is off before inserting or removing the battery.

Inserting the Battery

1. Open the battery/SD card cover in the direction of the [OPEN] arrow.

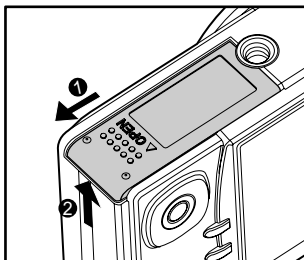

2. Insert the battery in the correct orientation shown.
 - Tilt the battery lock lever in the direction of the arrow, and then insert the battery.
3. Close the battery/SD card cover.

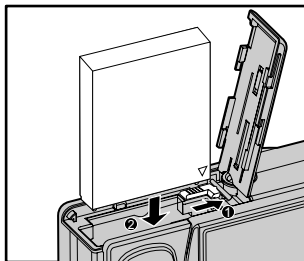

Removing the Battery

Open the battery/SD card cover and then release the battery lock lever. When the battery has come out a little, slowly pull it out the rest of the way.

Charging the Battery

Using the AC power adapter may charge the battery or operate the camera as power supply. Make sure that the power of the camera is off and then insert the battery before starting.

1. Insert one end of the AC power adapter into the **DC IN 5V** terminal of the camera.
2. Insert the other end of the AC power adapter into a wall outlet.
 - The status LED flashes green when charging is started and lights green when charging is completed. The LED lights red when a charging error has occurred.
 - It is recommended to fully discharge the battery before recharging.
 - Charging time varies according to the ambient temperature and the status of battery.

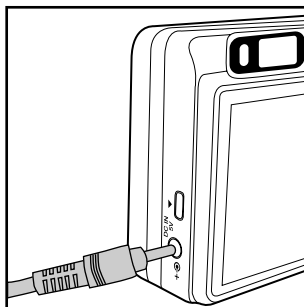

NOTE

- This camera must be used with specified AC power adapter. Damage caused by the use of an incorrect adapter is not covered under the warranty.
- Always make sure that the camera is off before removing the battery.
- The battery may feel warm after it has been charged or immediately after being used. This is normal and not a malfunction.
- When using the camera in cold conditions, keep the camera and battery warm by storing it in a warm place such as an interior pocket between shots.
- If you open the battery cover without removing the battery, the battery power will not be disconnected.
- If you remove the battery, you have to insert the battery within two hours in order to make sure that the date and time will not be reset.

Using an AC Power Adapter

Using an AC power adapter prevents the camera from automatically powered off while transferring files to your computer.

Perform the steps in the preceding section “Charging the Battery”.



NOTE

- Make sure to use only the AC power adapter specified for the digital video camera. Damage caused by the use of an incorrect adapter is not covered under the warranty.

Inserting and Removing an SD Card (Optional Accessory)

Images captured with the camera will be stored on a Secure Digital (SD) memory card. You must have an SD card in place to use the camera. Before inserting or removing the SD card, make sure that the power of the camera is off.

Inserting an SD card

- Open the battery/SD card cover.
- Insert the SD card in the correct orientation shown.
 - Hold the SD card with its front side (printed arrow) facing the rear side of the camera, and then insert the card as far as it can go. There will be a distinct click as the card seats fully into the card slot.
- Close the battery/SD card cover.

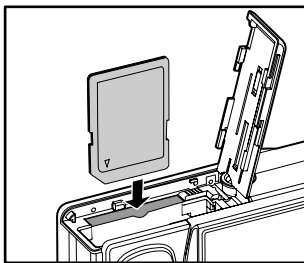

Removing an SD card

Open the battery/SD card cover, press lightly on the edge of the SD card and it will eject.



NOTE

- If the camera is powered on without an SD card inserted, a message “NO CARD” appears on the LCD monitor.
- To prevent valuable data from being accidentally erased from an SD card you can slide the write-protected tab (on the side of the SD card) to “LOCK”.
- However, to save, edit or erase data on an SD card, you must unlock the card.

Turning the Power On/Off

1. Load the battery or connect the AC power adapter to your camera.
2. Press the **POWER** button to turn on your camera.
 - The status LED lights green and the camera is initiated.
 - The power indicator lights on when the camera power is turned on.
 - When the power is turned on, the camera will start in the mode that is currently selected.
3. To turn off your camera, press the **POWER** button again.

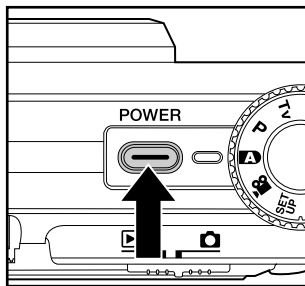

NOTE

- The power is turned off automatically when the camera has not been operated for a defined period time. To resume the operation condition, turn the power on again. Refer to section in this manual titled “**Auto PoFF**” in the **Setup Menu (Basic tab)** for further details.
- When the power is turned on, it may take several seconds to charge the flash. While the flash is being charged, the status LED lights orange. The camera is not ready until the flash has charged. The camera is ready when the status LED is off.

Setting the Date and Time

The date/time needs to be set if/when:

- Camera is turned on for the first time.
- Camera is turned on after leaving the camera without the battery for an extended period of time.

When the date and time information is not displayed on the LCD monitor, follow these steps to set the correct date and time.

1. Slide the mode switch to **[CAM]** and set the mode dial to **[SETUP]**.
 - The setup menu is displayed.

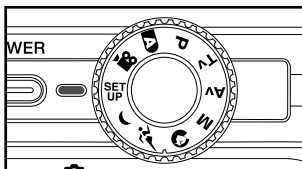

2. Select **[Custom]** with the **◀/▶** buttons.
3. Select **[Date/Time]** with the **▲/▼** buttons, and press the **SET** button.
 - The Date/Time setting screen will be displayed.

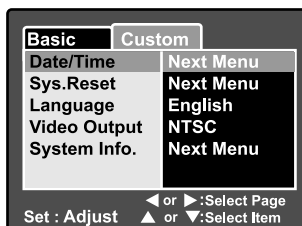

4. Select the item's field with the **◀/▶** buttons and adjust the value for the date and time with the **▲/▼** buttons.
 - The date and time is set in the order year-month-day-hour-minute.
 - The time is displayed in 24-hours format.
5. After confirming all settings are correct, press the **SET** button.
 - The setting will be stored and the screen will return to the setup menu.



Choosing the Display Language

Choose an On-Screen Display (OSD) language for information to be displayed on the LCD monitor.

1. Slide the mode switch to [CAM] and set the mode dial to [SET].

- The setup menu is displayed.

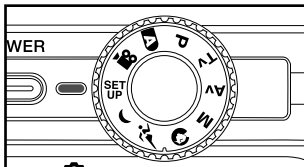

2. Select [Custom] with the ◀/▶ buttons.
3. Select [Language] with the ▲/▼ buttons, and press the **SET** button.
 - The available OSD languages will be displayed.
4. Select the displayed language with the ▲/▼ buttons and press the **SET** button. The setting will be stored.

Formatting an SD Memory Card

Formatting an SD card will erase all of the images and folders that have been recorded on the SD card. Formatting is not possible when the SD card is in the locked condition.

- Slide the mode switch to [CAM] and set the mode dial to [P].

- [Basic] of the setup menu is displayed.

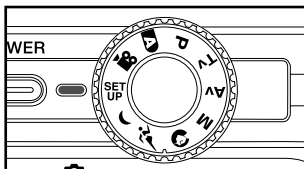

- Select [Format] with the ▲/▼ buttons, and press the **SET** button.

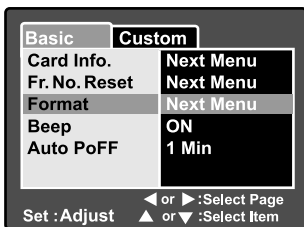

- Select [Execute] with the ▲/▼ buttons, and press the **SET** button.

- To cancel formatting, select [Cancel].

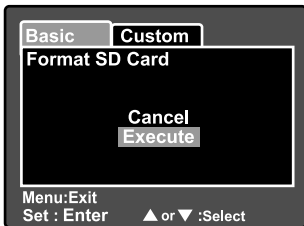

NOTE

- You need to format an SD card before using it in this camera.
- Formatting an SD card erases everything from the memory card including images, videos, and also non-image data. Before formatting, make sure that all data is unnecessary.
- Formatting is an irreversible action and data cannot be recovered at a later time.

Setting Image Resolution and Quality

Resolution and quality settings determine the pixel size (dimension), image file size, and compression ratio for your images. These settings affect the number of images that can be stored on a memory card. As you get to know the camera, it is recommended that you try each quality and resolution setting to get an appreciation for the effects that these settings will have on your images.

Higher resolution and higher quality images offer the best photographic results, but produce large file sizes. Therefore, few images will take up a lot of memory space.

High resolution and quality settings are recommended for printed output and situations requiring the finest detail. Lower resolution/quality images take up less memory space and may be quite suitable for sharing images via e-mail, in a report, or on a web page.

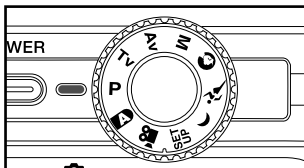

To change image resolution or image quality, perform these steps below:

- Slide the mode switch to **[P]** and set the mode dial to one of the photography modes.
 - **[Picture]** of the photography menu is displayed.
- Press the **MENU** button.
 - Select **[Size]** with the **▲/▼** buttons, and press the **SET** button.
 - Select the desired setting with the **▲/▼** buttons, and press the **SET** button.
- Select **[Quality]** with the **▲/▼** buttons, and press the **SET** button.
- Select the desired setting with the **▲/▼** buttons, and press the **SET** button.
- To exit from the photography menu, press the **MENU** button.



Possible number of shots (still image)

The following table shows the approximate shots that you can capture at each setting based on an optional SD card.

Image size	Quality	SD card capacity					
		32MB	64MB	128MB	256MB	512MB	1GB
 (8M) 3264 x 2448	★★★ Fine	7	14	28	57	115	223
	★★ Standard	13	28	57	113	229	441
	★ Economy	27	55	111	222	448	863
	TIFF TIFF	1	3	8	15	32	61
 (5M) 2560 x 1920	★★★ Fine	11	23	46	93	188	362
	★★ Standard	22	45	92	183	369	711
	★ Economy	43	88	178	354	714	1,374
 (2M) 1600 x 1200	★★★ Fine	28	57	116	232	468	902
	★★ Standard	54	110	223	445	897	1,727
	★ Economy	99	204	412	821	1,653	3,182
 (VGA) 640x 480	★★★ Fine	145	298	602	1,200	2,417	4,650
	★★ Standard	237	484	979	1,951	3,927	7,557
	★ Economy	379	775	1,566	3,121	6,284	12,092

Possible recording time/sec (video clip)

Image size	Quality	SD card capacity					
		32MB	64MB	128MB	256MB	512MB	1GB
 640 x 480	★★★ Fine	0:20	0:41	1:23	2:46	5:23	10:46
	★★ Standard	0:27	0:55	1:52	3:45	7:15	14:31
	★ Economy	0:54	1:51	3:44	7:27	14:25	28:51



NOTE

- The data shows the standard testing results. The actual capacity varies according to the shooting conditions and settings.

PHOTOGRAPHY MODE

[**A**] Auto Mode

Auto photography mode is perhaps the most commonly used photography mode. Images can be captured simply because the exposure (the combination of shutter speed and aperture setting) is determined automatically to suit the photographic conditions.

You can use either the optical viewfinder and/or the 2.5" LCD monitor to compose your images. Capturing images using the optical viewfinder will conserve the battery power. If the battery power is low, it is recommended that you only compose images using the viewfinder. Using the LCD monitor, you can compose images more accurately, but at the cost of the battery consumption. Always use the LCD display for close-up macro shots.

Using the Optical Viewfinder

Make sure that the battery and SD card are inserted before capturing images.

1. Press the **POWER** button to turn on the camera.
2. Slide the mode switch to [**Q**] and set the mode dial to [**A**].

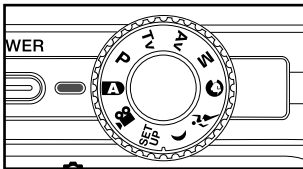
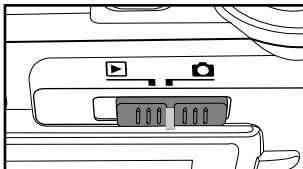

3. Compose your image in the viewfinder.
 - Turn the "diopter adjustment dial" until the image appears clearly within the viewfinder.

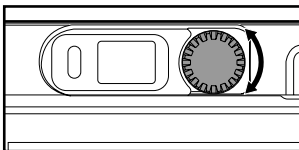

4. Press the shutter button down halfway.
 - Pressing the shutter button down halfway automatically focuses and adjusts the exposure.
 - The focus-area frame turns blue and the status LED lights green when the camera is focused and exposure is determined.
 - When the focus or exposure is not suitable, the frame of the focus area turns yellow and the status LED flashes red.
5. Press the shutter button down fully to capture the image.
 - If the photographic preview is set to "ON", images (the captured image) will be displayed while the image is being recorded onto the memory.
 - When the voice memo is set to "ON", [VOICE RECORDING] will be displayed on the screen immediately after the image is captured and voice memo recording will start.
 - Press the shutter button one more time during recording, or wait for 30 seconds, [VOICE RECORD END] will be displayed and the recording will end. A [📷] icon is displayed with images that have been recorded with a voice memo.

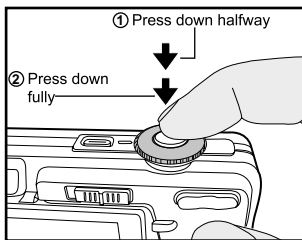

Using the LCD Monitor

Make sure that the battery and SD card are inserted before capturing images.

1. Press the **POWER** button to turn on the camera.
2. Slide the mode switch to [📷] and set the mode dial to [A].
 - By default, the LCD monitor setting is on.
3. Compose your image in the LCD monitor.
4. Press the shutter button down halfway, then press it down fully.

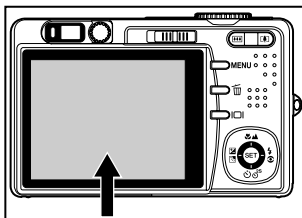

Using the Optical Zoom

Zoom photography allows you to capture images magnified up to 3 times or wide-angle photography depending on the distance up to the subject. You can also enlarge the center of the screen and capture images in the digital zoom mode.

1. Slide the mode switch to [📷] and set the mode dial to one of the photography modes.
2. If required, turn on the LCD monitor by pressing the [LCD] button.
3. Compose the image with the zoom button.
 - Pressing the [🔍] button zooms in on the subject, and enlarges the subject on the LCD monitor.
 - Pressing the [👁️] button provides a wider-angle image.
 - The lens position moves according to the zoom button setting.
4. Press the shutter button down halfway to set the focus and exposure, then press it down fully to capture the image.

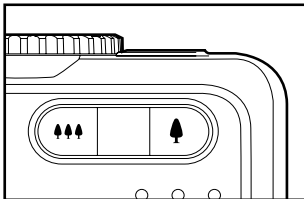

Using the Digital Zoom

Using a combination of 3 times optical zoom and 5.1 times digital zoom permits zoom photography up to 15.3 times to suit the subject and the distance. Digital zoom is a compelling feature, however, the more an image is enlarged (zoomed), the more pixelated (grainer) the image will appear.

1. Slide the mode switch to and set the mode dial to one of the photography modes.
2. Turn on the LCD monitor by pressing the button.
3. To enable the digital zoom:
 - a. Press the **MENU** button.
 - b. Select [Function] with the buttons.
 - c. Select [Digital Zoom] with the , and press the **SET** button.
 - d. Select [ON] with the , and press the **SET** button.
 - e. Press the **MENU** button to exit from the menu screen.
 - f. To activate the digital zoom, press and hold the button completely until the image on the LCD monitor expands.
4. Press the shutter button to capture a “zoomed” image.

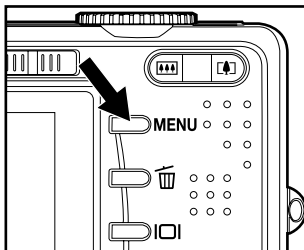

Picture	Function	AE/AWB
Capture Mode	Single	
Voice Memo	OFF	
LCD Bright.	0	
Digital Zoom	ON	
Preview	OFF	
Date Print	ON	
Menu:Exit ◀ or ▶:Select Page		
Set : Adjust ▲ or ▼:Select Item		

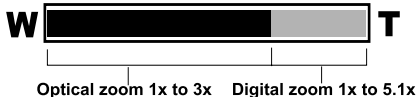

- Digital zoom cannot be activated in the mode.
- The digital zoom is cancelled when the LCD monitor is turned off.
- The zoom setting is automatically cancelled by either turning the camera off or the activation of the Auto Power Off function.

Setting the Flash

Set the flash for capturing images. The flash mode can be selected for the particular photographic conditions.

- Slide the mode switch to and set the mode dial to one of the photography modes.

- The available flash modes are dependant on the selected photography mode, scene mode, and capture mode.

- Toggle the button to select the desired flash mode.

- Each press of the button moves the icon one step through the sequence and displays it on the screen.
- For the automatic mode :

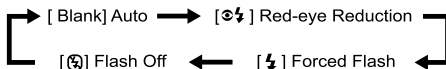

- For the modes , , and .

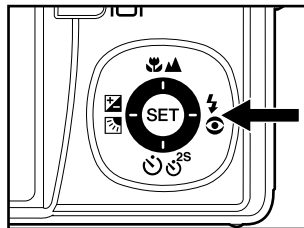
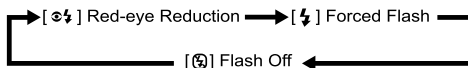

The table below will help you choose the appropriate flash mode:

Flash mode	Description
[Blank] Automatic	The flash fires automatically to suit the photographic conditions. This mode is only available when the camera is set to the [A] mode.
[Red-eye] Red-eye Reduction	Use this mode to reduce the red-eye phenomenon when you want to capture natural-looking images of people and animals in low-light conditions. When the camera mode is [A] and [P], the flash will fire to suit the brightness of the subject. When the camera mode is [Tv], [Av] and [M], the flash will always fire.
[Flash] Forced Flash	In this mode, the flash always fires. Use this mode for photographing under artificial light such as backlighting, fluorescent lighting, etc.
[Flash Off] Flash Off	Use this mode when capturing images using indoor lighting, for stages and indoor competitions, and when the subject is too far away for the flash to be effective.



NOTE

- In [Portrait] portrait mode, the flash mode is fixed to [Red-eye] Red-eye Reduction.
- In [Sports] sports mode, the flash mode is fixed to [Flash Off] Flash Off.
- In [Night] night-scene mode, the flash mode is fixed to [Flash] Forced Flash.
- In [Landscape] landscape-focus mode, the flash mode is fixed to [Flash Off] Flash Off.
- The flash cannot be used in the [Movie] movie mode and burst mode [Continuous] and [Auto Exp.].

Setting the Focus

Images can be captured with the focus determined automatically using auto focus. You may over-ride the auto focus and specify [👁] macro or [▲] infinity. The focus setting will be maintained even when the power is turned off or when Auto Power Off is activated. The available focus settings will depend on the selected photography mode.

- Slide the mode switch to [📷] and set the mode dial to one of the photography modes.
- Toggle the [👁▲] button to select the desired focus mode.
 - Each press of the [👁▲] button moves the icon one step through the sequence and displays it on the screen.
 - For the modes of [📷], [P], [Tv], [Av], [M], [S] and [B]:

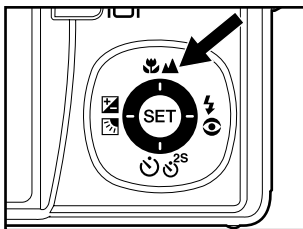

- For the modes of [📷] and [📷]:



The table below will help you choose the appropriate focus mode:

Focus mode	Description
[Blank] Auto Focus	Select auto focus for most occasions when you want the camera to automatically determine the focus setting. Using auto focus any object at a range of focus is 50 cm or greater can be in focus.
[👁] Macro	Select macro to capture close-up images. When the lens is zoomed to its widest position you may focus objects as close as 5 cm. When the lens is zoomed to its telephoto position (3x zoom) you may focus objects as close as 30 cm.
[▲] Infinity	Select the infinity-focus setting when you want to capture images of subjects at a distance of infinity.

Setting the Self-timer

This setting allows images to be captured with the self-timer.

- Slide the mode switch to [📷] and set the mode dial to one of the photography modes.
- Toggle the  button to select the setting.

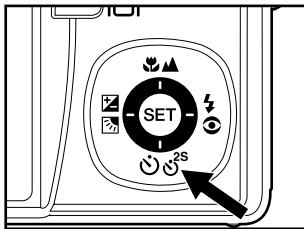

- Each press of the button moves the icon one step through the sequence and displays it on the screen.

OFF → [🕒 10S] 10 sec. → [🕒 2S] 2 sec.
 [🕒 10+2] 10+2 sec.

- For the [🎥] movie mode and burst mode ([Continuous] and [Auto Exp.]):

OFF → [🕒 10S] 10 sec. → [🕒 2S] 2 sec.

- Compose the image, press the shutter button down halfway, then press it down fully.
 - The self-timer LED flashes and the image will be captured after the preset time has elapsed.
 - The countdown is displayed on the LCD monitor.
 - To cancel the self-timer during operation, press the **SET** button.

The table below will help you choose the appropriate self-timer mode:

Self-timer mode	Description
[🕒 10S] 10 sec.	The image is captured about 10 seconds after the shutter button is pressed.
[🕒 2S] 2 sec.	The image is captured about 2 seconds after the shutter button is pressed.
[🕒 10+2] 10+2 sec.	The first image is captured about 10 seconds after the shutter button is pressed, and then the second image is captured 2 seconds later. The 10+2 mode is convenient when capturing group images in succession.



NOTE

- The self-timer setting is automatically cancelled after an image is captured.
- Use of the [🕒 2S] self-timer setting is effective in preventing motion-blur that can result when the shutter button is pressed at long exposure times. Use this mode and a tripod for best results.

Exposure Compensation/Backlight Correction

Images can be captured with the overall scene intentionally made brighter or darker. These settings are used when a suitable brightness (exposure) cannot otherwise be obtained in circumstances where the difference in brightness between the subject and the background (the contrast) is large, or when the subject that you wish to capture is very small within the scene. Exposure can be set in 0.3 EV units.

- Slide the mode switch to and set the mode dial to [P], [Tv], [Av] and press the button.
 - Each press of the button displays the setting in the order of [Blank], Backlight Correction, and Exposure Compensation.
- Set the exposure value with the / buttons.

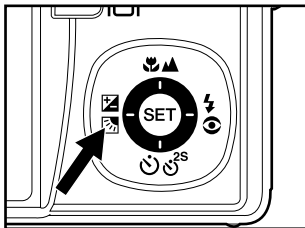

- Press the button to increase the value.
- Press the button to decrease the value.
- The setting range of the exposure compensation is as follows: -2.0, -1.7, -1.3, -1.0, -0.7, -0.3, 0, +0.3, +0.7, +1.0, +1.3, +1.7, +2.0.
- The larger the value, the brighter the image. The smaller the value, the darker the image. The set value is displayed on the screen.

Effective Subjects and Set Values

- + (positive) compensation**
 - * Printed matter comprising black text on whitish paper
 - * Backlighting
 - * Bright scenes or strong reflected light such as ski slopes
 - * When the sky accounts for a large area on the screen
- (negative) compensation**
 - * People illuminated by a spotlight, in particular, against dark background
 - * Printed matter comprising white text on blackish paper
 - * Weak reflecting bodies such as evergreen trees or darkish leaves
- Backlight correction (+1.3 EV, fixed)**
 - * When the background is bright and the subject is dark.
 - * When subjects (people) have a light source such as the sun to their backs.



- The backlight correction setting can be set in the [Av], [P], [Tv], [Av], and modes.

[P] Program (Automatic Exposure) Photography Mode

The camera automatically sets the shutter speed and the aperture to suit the brightness of the subject. This allows you to capture image with ease just like when the [A] mode is selected.

1. Slide the mode switch to [P] and set the mode dial to [P].
2. Compose the image, press the shutter button down halfway, then press it down fully.

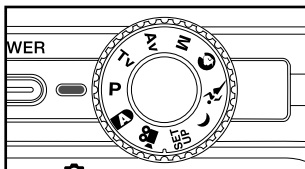

NOTE

- Exposure compensation can be set.

[Tv] Shutter Speed Priority Photography Mode

In this mode, images are captured with the priority given to shutter speed. The aperture is automatically set according to the shutter speed. If you set a fast shutter speed, you can capture images of moving subjects that look as if they are still. If you set a slow shutter speed, you can capture images that give the impression that the subject is in motion.

- Slide the mode switch to [Ⓜ] and set the mode dial to [Tv].
- Press the **SET** button.

- After pressing the **SET** button in [Tv] mode, the /▲/Ⓢ buttons turn into ▲/▼ buttons for adjusting shutter speed.
- Pressing the **SET** button again, the ▲/▼ buttons return to focus setting/self-timer function.

- Set the shutter speed with the ▲/▼ buttons.

- Press the ▲ button to select faster shutter speeds.
- Press the ▼ button to select slower shutter speeds.

- The setting range of the shutter speed is as follows:
1/1500, 1/1250, 1/1000, 1/820, 1/650, 1/500, 1/400, 1/320, 1/250, 1/200, 1/160, 1/125, 1/100, 1/80, 1/64, 1/50, 1/40, 1/32, 1/25, 1/20, 1/16, 1/13, 1/10, 0.13s, 0.16s, 0.2s, 0.25s, 0.3s, 0.4s, 0.5s.

- The shutter speed and corresponding aperture value are displayed on the screen. If an appropriate combination cannot be set, the aperture value is displayed in red, but images can be captured regardless.

- Compose the image, press the shutter button down halfway, and then press it down fully.

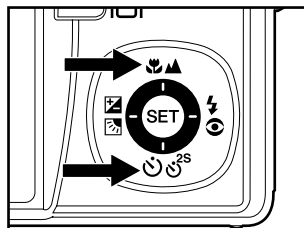
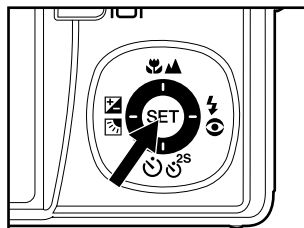
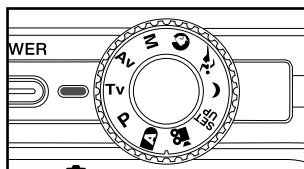

NOTE

- In the flash photography mode, when [⚡] and [Ⓢ] are set, the fastest shutter speed is 1/250 second.

[Av] Aperture Priority Mode

In this mode, images are captured with the priority given to aperture. The shutter speed is automatically set according to the aperture. The aperture will affect the depth-of-field of the camera.

If you set a small aperture (higher F value), you can capture portrait images with an out-of-focus background. Alternatively, if you set a large aperture (lower F value), both close objects and distant objects will be in focus, for example when capturing landscape images.

- Slide the mode switch to [P] and set the mode dial to [Av].
- Press the **SET** button.
 - After pressing the **SET** button in [Av] mode, the /▲/⬆️ buttons turn into ▲/▼ buttons for adjusting aperture value.
 - Pressing the **SET** button again, the ▲/▼ buttons return to focus setting/self-timer function.
- Set the aperture value with the ▲/▼ buttons.
 - Press the ▲ button to increase the value.
 - Press the ▼ button to decrease the value.
 - The setting range of the aperture value is as follows:
F6.7, F5.6, F4.8, F4.0, F3.5, F2.8.
 - The aperture value and corresponding shutter speed are displayed on the screen. If an appropriate combination cannot be set, the shutter speed is displayed in red, but images can be captured regardless.
- Compose the image, press the shutter button down halfway, and then press it down fully.

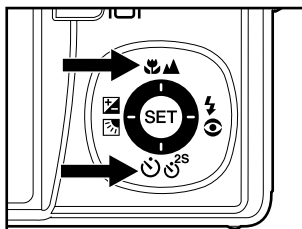
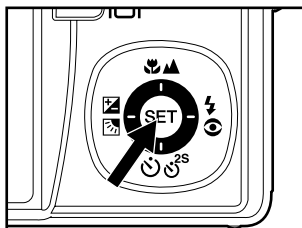
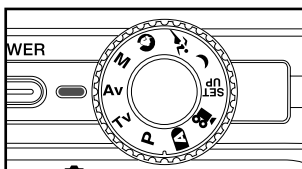

NOTE

- The aperture value varies depending on the position of the zoom lens.

[M] Manual Mode

In manual mode, the aperture value and the shutter speed can be varied individually.

- Slide the mode switch to [M] and set the mode dial to [M].
- Press the **SET** button.
 - After pressing the **SET** button in [M] mode, the buttons turns into buttons for adjusting shutter speed.
 - After pressing the **SET** button in [M] mode, the buttons turns into buttons for adjusting aperture value.
 - Pressing the **SET** button again, the buttons returns to focus setting/self-timer/exposure compensation/flash setting function.
- Set the shutter speed with the buttons.
- Set the aperture value with the buttons.
- Compose the image, press the shutter button down halfway, and then press it down fully.

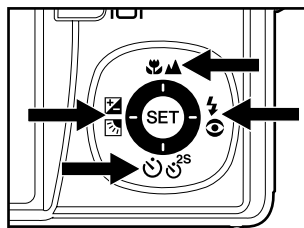
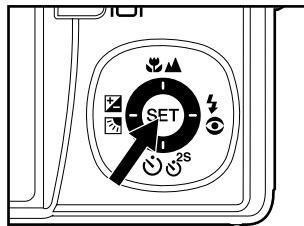
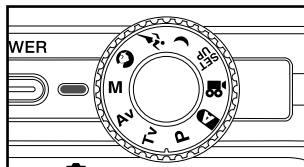

NOTE

- In the flash photography mode, when [⚡] and [⚡] are set, the fastest shutter speed is 1/250 second.

Setting the Scene Mode

This sets the scene setting such as [👤] portrait, [🏃] sports or [🌃] night scene and captures the image.

- Slide the mode switch to [📷] and set the mode dial to one of the scene modes.
 - When the camera mode is set to the [👤] or [🌃], [🌸] macro cannot be selected.
- Compose the image, press the shutter button down halfway, then press it down fully.

The table below will help you choose the appropriate scene mode:

Scene mode	Description
[👤] Portrait	Select portrait mode when you want to capture an image that makes the person stand out against a defocused (blurred) background. The flash setting is fixed at [🔇] which is effective in reducing the red-eye phenomenon.
[🏃] Sports	Select sports mode when you want to photograph fast-moving subjects. In this mode, the flash mode cannot be used.
[🌃] Night scene	Select night-scene mode when you want to photograph people with an evening or night scene background. The flash is fixed at [🔇].





NOTE

- The description of each scene serves as a general guide. Set the camera to suit your own preferences.



[] Movie Mode

This mode allows you to record video clips at a resolution of 640 x 480 pixels. Voice can also be recorded.

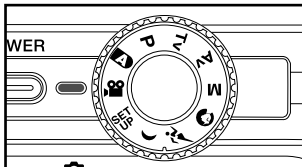
- Slide the mode switch to [] and set the mode dial to [].
- Compose the image with the zoom button.
 - Optical zoom should be set while composing the scene.
 - Zoom function cannot be used during movie capture.
- Fully press down the shutter button.
 - The recording of the video clip will start.
 - Pressing the shutter button again will end the recording and save the video on the SD card.
 - The recording time depends on the storage size and the subject of the image to be recorded.



NOTE

- Digital zoom cannot be activated in the [] mode.
- In the [] mode, the LCD monitor cannot be turned off.
- When recording video clips, the flash cannot be used.
- While the image is being recorded into the SD card, do not open the battery/SD card cover, nor remove the battery or SD card. Doing so might damage the SD card or destroy the data.
- If the access speed of your SD card is not enough for recording video clips in the currently selected quality, a warning icon [] will appear, and then the movie recording will stop. In this case, select a video quality lower than the current one.

[▶] PLAYBACK MODE

Playing Back Still Images

You can play back the still images on the LCD monitor. Insert the SD card into the camera and turn on the power before starting.

- Slide the mode switch to [▶].
 - The last image appears on the screen.
- The images can be fed in reverse or fed forward with the ▲/▼ buttons.

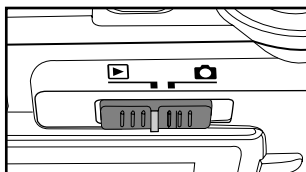
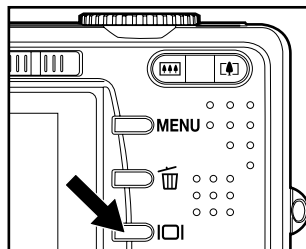

Image Display Information

You can switch the state of the information display by pressing the [I/O] button when playing back images. Each press of the [I/O] button switches the information display state in the following order:



NOTE

- Pressing the ◀/▶ buttons during image playback will rotate the image 90 degrees. The ▶ button rotates the image clockwise, whereas the ◀ button rotates the image counterclockwise. A press of the button opposite to the direction in which the image was rotated will return the image to the normal display.
- A [▶] icon is displayed with the video data. Video clips cannot be rotated.
- A [🗣️] icon is displayed with images which have an audio memo recorded.
- Press the **SET** button to play back voice memos.
- In zoom playback, the display is switched between normal and non-display.

Playing Back Video Clips

You can play back video clips recorded on the camera. You can also play back voice.

- Slide the mode switch to [📺].
 - The last image appears on the screen.
- Select the desired video clip with the ▲/▼ buttons.
 - A [📺] icon is displayed with the video data.
- Press the **SET** button to play back a video clip.
 - Pressing the ▶/◀ buttons during playback initiates fast forward/fast reverse.

Button Operations for Video Playback:

	During Playback	During Pause	During a Stop
▶ button	(Forward play) Pressing the ▶ button will sequentially invoke 2x fast-forward, 4x fast-forward, regular play.	1-frame feed	
◀ button	(Reverse play) Pressing the ◀ button will sequentially invoke 2x fast-reverse, 4x fast-reverse, regular play.	Reverse 1-frame feed	
▲ button	Sound On/Off		The previous image is displayed.
▼ button	Stop (The display returns to the 1st frame playback)		The next image is displayed.
SET button	Pause	Cancels pause	Regular forward play



NOTE

- Video clips cannot be displayed rotated or enlarged.

Playing Back Still Images/Video Clips on a TV

You can also play back your images on a TV screen. Before connecting to any video devices, make sure to select NTSC/PAL to match the broadcast standard of the video equipment you are going to connect to the camera. It is recommended to use the AC power adapter while transferring the recorded images and video files.

1. Slide the mode switch to [▶].
2. Connect one end of the A/V cable to the **A/V OUT** terminal of the camera.
3. Connect the other end to the A/V input socket of the TV set.
4. Turn the TV and camera on.
5. Play back the still images/video clips.
 - The method of operation is the same as playing back still images and video clips on the camera.

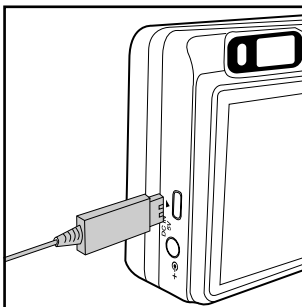

NOTE

- On PAL systems, images are surrounded by a black frame.
- Refer to the section in this manual titled “**Video Output**” in the **Setup Menu (Custom tab)** for further details.

Attaching Voice Memos

A maximum of 30 seconds of audio can be recorded like a memo annotation for each still image. The voice memo can be recorded only once.

1. Slide the mode switch to [📷].
 - The last image appears on the screen.
2. Select the image that you want to attach the voice memo with the ▲/▼ buttons.
3. Press the shutter button.
 - [VOICE RECORDING] is displayed on the screen and recording starts.
4. To stop recording voice memo during recording, press the shutter button again.
 - [VOICE RECORD END] will be displayed and the recording will end.
A [🗣️] icon is displayed with images that have been recorded with a voice memo.

Playing back voice memo

Pressing the **SET** button displays [VOICE PLAYBACK] and plays back the voice memo.



NOTE

- Voice memo is available at the time of still single image capture mode as well as during playback.

Thumbnail Display

This function allows you to view nine thumbnail images on the LCD monitor simultaneously, so you can quickly search for the image that you want.

- Slide the mode switch to [D].
 - The last image appears on the screen.
- Press the **◆◆◆** button.
 - The images are displayed in the thumbnail display.
 - Images that have been selected with the **▲/▼/◀/▶** buttons will be indicated by a green frame.
 - When there are ten or more images, scroll the screen with the **▲/▼** buttons.
- Press the **▲/▼/◀/▶** buttons to select the image to be displayed at regular size.
- Press the **SET** button.
 - The selected image is displayed at its regular size.



NOTE

- As appropriate, the [G], [L], [R], [A] icon will be displayed in a thumbnail display.

Zoom Playback

Images that are played back can be enlarged by a factor of two, or four times. This allows you to enlarge a selected portion of an image to examine fine details.

- Slide the mode switch to [P].
- Press the ▲/▼ buttons to select the image you want to enlarge.
 - You can also select the image you want to enlarge from the thumbnail display.
- Adjust the zoom ratio with the ⬆/⬇ buttons.
 - Pressing the ⬆ button enlarges the image.
 - To return to normal magnification, press the ⬇ button.
 - The magnification factor is displayed on the LCD monitor.
 - The image is displayed enlarged, and a white frame and green frame are displayed on the LCD monitor.
 - The white frame indicates the entire image, while the green frame shows the location of the currently enlarged area.
- Press the ▲/▼/◀/▶ buttons to select the area to enlarge.
- To return to regular display, toggle the ⬇ button until the regular display appears on the screen.

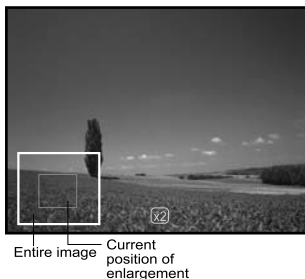

NOTE

- Pressing the ⬆ button magnifies the image from 1x → 2x → 4x.
- Pressing the ⬇ button reduces the image from 4x → 2x → 1x.

Slideshow Display

The slideshow function enables you to play back your still images automatically in sequential order as a slideshow. This is very useful and entertaining feature for reviewing captured images and for presentations.

- Slide the mode switch to [▶].
- Press the **MENU** button.
 - The playback menu is displayed.
- Select [Slide Show] with the ▲/▼ buttons, and press the **SET** button.
 - The slideshow starts.
- To stop the slide show during playback, press the **SET** button.
 - The image is displayed on screen when you press the **SET** button.



NOTE

- The Auto Power Off function is disabled during a slide show.
- All still images in the folder are automatically played back.

Protecting Images

You may protect an image from accidental deletion, or erasure.

Protecting Images

- Slide the mode switch to [▶].
- Select the image that you want to protect with the ▲/▼ buttons.
- Press the **MENU** button.
 - The playback menu is displayed.
- Select [Protect] with the ▲/▼ buttons, and press the **SET** button.
- Select [Single] or [All] with the ▲/▼ buttons, and press the **SET** button.
- Select [Set] with the ▲/▼ buttons, and press the **SET** button.
 - Protection is applied to the image and the camera returns to the playback mode.
 - The protect icon [🔒] is displayed with protected images. When [All] has been selected, [🔒] is displayed with all images.

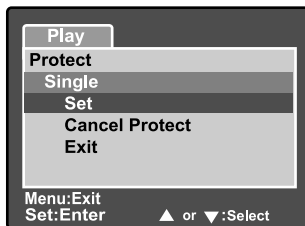
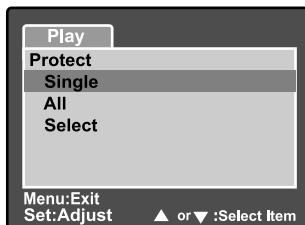

Canceling Protection

To cancel protection for only one image, display the image that you want to remove the image protection.

- Select [Protect] with the ▲/▼ buttons from the playback menu, and press the **SET** button.
- Select [Single] or [All] with the ▲/▼ buttons, and press the **SET** button.
- Select [Cancel Protect] with the ▲/▼ buttons, and press the **SET** button.
 - The image is no longer protected and the camera returns to playback mode.

Protecting multiple images

1. Select [Protect] with the ▲/▼ buttons from the playback menu, and press the **SET** button.
2. Select [Select] with the ▲/▼ buttons, and press the **SET** button.
 - The images are displayed in the thumbnail display.
3. Select the image you want to protect with the ▲/▼/◀/▶ buttons, and press the |□| button.
 - The protect icon [🔒] is displayed with protected images. Selecting a protected image and pressing the |□| button again will cancel the protection.
4. Press the **SET** button.
 - The camera returns to playback mode.





NOTE

- Formatting an SD card overrides protection, and erases all images regardless of their protected status.

Deleting Images

Immediate Erasure (Quick Delete Function)

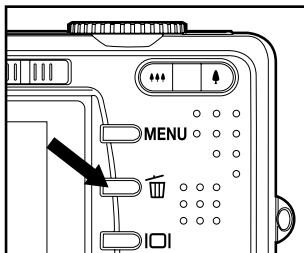

The quick delete function enables you to delete the last-captured image during capture.

- Slide the mode switch to  and set the mode dial to one of the photography modes.
- Press the  button.
 - The last image and quick delete menu appear on the screen.
- Press the  button again to delete the image.
 - You may also press the **SET** button to confirm the deletion.
 - To not delete, select [Cancel], and press the **SET** button.



Deleting in Playback Mode

Deleting a single image/Deleting all images

- Slide the mode switch to .
 - The last image will be displayed on the screen.
- Select the image you want to delete with the \blacktriangle / \blacktriangledown buttons.
- Press the  button.
 - The deletion menu will be displayed.
- Select [Single] or [All] with the \blacktriangle / \blacktriangledown buttons, and press the **SET** button.
 - [Single]: Deletes the selected image or the last image.
 - [All]: Deletes all of the images on the SD card except for protected images.
 - [Select]: Deletes a set of selected images.

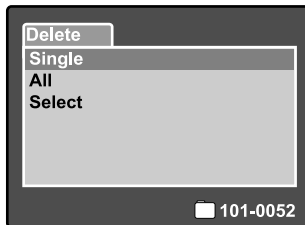



- Select [Execute] with the ▲/▼ buttons, and press the **SET** button.
 - To not delete, select [Cancel], and press the **SET** button.

**NOTE**

- Deleting an image will not affect sequential image numbering. For example, if you delete image number 240, the next captured image will be numbered 241 even though 240 no longer exists. In other words, an image-number is retired when an image is deleted and will not be reused or reassigned to another subsequently captured image.

Deleting selected images

This deletes a number of selected images.

- Slide the mode switch to [D].
- Press the  button.
 - The deletion menu will be displayed.
- Select [Select] with the ▲/▼ buttons, and press the **SET** button.
 - The images are displayed in the thumbnail display.
- Select the image you want to delete with the ▲/▼/◀/▶ buttons, and press the  button.
 - The  icon will be displayed. One more press of the delete button will cancel the operation. Repeat this procedure and select all the images that you want to delete.
- Press the **SET** button.

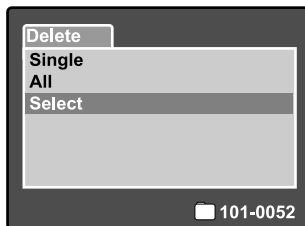

DPOF Settings

DPOF (Digital Print Order Format) allows you to embed printing information on your memory card. Files saved in the DPOF format can be printed using compatible printers or through a laboratory printing device.

1. Set the mode dial to [P].
2. Select the image that you want to set DPOF with the ▲/▼ buttons.
3. Press the **MENU** button.
 - The playback menu is displayed.
4. Select [DPOF] with the ▲/▼ buttons, and press the **SET** button.
 - The DPOF setting screen is displayed.



5. Select [Single] or [All] with the ▲/▼ buttons, and press the **SET** button.
 - [Single]: Sets DPOF for each individual image.
 - [All]: Sets DPOF for all images at once.

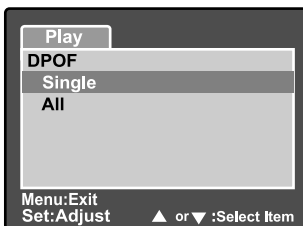

6. Select [Print Num.] with the ▲/▼ buttons, and press the **SET** button.
 - This displays the number of prints setting screen.
7. Set the number of prints with the ▲/▼ buttons, and press the **SET** button.
 - You can set up to 9 prints for each image.
8. Select [Date] with the ▲/▼ buttons, and press the **SET** button.
 - The date and time setting screen appears.

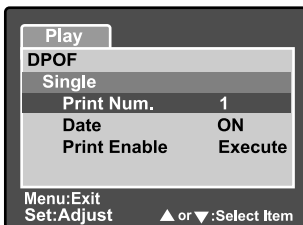

9. Select date to [ON] or [OFF] with the ▲/▼ buttons, and press the **SET** button.

[ON]: The date of the photograph will also be printed.

[OFF]: The date of the photograph will not be printed.

10. Select [Print Enable] with the ▲/▼ buttons, and press the **SET** button.

11. Select [Execute] with the ▲/▼ buttons, and press the **SET** button.

- This creates a file containing the DPOF information, and when the operation is finished, the screen returns to the playback screen.

- The DPOF icon [🖨️] is displayed on each image that have set up DPOF settings.



NOTE

- The date that is printed on the photo is the date set on the camera. To print the correct date on the photo, set the date on the camera before you capture the image. Refer to the section in this manual titled “**Setting the Date and Time**” for further details.

MENU OPTIONS

Photography Menu (Picture tab)

This menu is for basic settings used when capturing images in the photography modes. These settings are retained even if the camera is turned off or the Auto Power Off function is activated.

- Slide the mode switch to and set the mode dial to one of the photography modes.
- Press the **MENU** button.
 - The [Picture] tab of the photography menu is displayed.
- Select the desired [Picture] option item with the \blacktriangle / \blacktriangledown buttons, and press the **SET** button to enter its respective menu.
- Select the desired setting with the \blacktriangle / \blacktriangledown buttons, and press the **SET** button.
- To exit from the photography menu, press the **MENU** button.

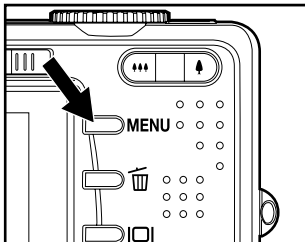

Size (resolution)

This sets the resolution of the still-image that will be captured.

[Still image]

- 3264 x 2448**: 3264 x 2448 pixels
(8 Megapixel resolution)
- 2560 x 1920**: 2560 x 1920 pixels
(5 Megapixel resolution)
- 1600 x 1200**: 1600 x 1200 pixels
(2 Megapixel resolution)
- 640 x 480**: 640 x 480 pixels
(VGA resolution)

Picture	Function	AE/AWB
Size	3264x2448	
Quality	Standard	
Sharpness	Normal	
Contrast	Normal	
Color	Standard	
Menu:Exit	\blacktriangleleft or \blacktriangleright	:Select Page
Set :Adjust	\blacktriangle or \blacktriangledown	:Select Item



- The size setting is not available in the mode.

Quality

This sets the quality (compression rate) at which the image is captured.

Fine: Low compression

Standard: Normal

Economy: High compression

TIFF: Lossless compression (the absolute highest image quality and the largest file sizes.)



NOTE

- TIFF setting is only available at resolution 3264 x 2448.
- TIFF uses lossless compression for the absolute finest possible image detail.

Sharpness

The camera can automatically emphasize the borders between light and dark areas of the image. This will make the image's edges look sharper. In some scenes you may prefer sharper edge detail. In other scenes you may prefer softer edge detail.

This sets the sharpness of the image that will be captured.

Hard: Hard

Normal: Normal

Soft: Soft



NOTE

- Sharpness cannot be set in the [,] mode.

Contrast

This sets the difference between the bright and dark portions of the images that will be captured.

Hard: Increases the contrast.

Normal: Set the contrast automatically.

Soft: Decreases the contrast.

Color

This allows you to specify the color mode of the images that will be captured.

Standard: Standard color

Vivid: Bright color (more color saturation)

Sepia: Sepia

Monochrome: Black-and-white (grayscale images with the effect of black and white film)

Photography Menu (Function tab)

- Slide the mode switch to [📷] and set the mode dial to one of the photography modes.
- Press the **MENU** button, and select the [Function] menu with the ► button.
 - The [Function] tab of the photography menu is displayed.
- Select the desired [Function] option item with the ▲/▼ buttons, and press the **SET** button to enter its respective menu.
- Select the desired setting with the ▲/▼ buttons, and press the **SET** button.
- To exit from the photography menu, press the **MENU** button.

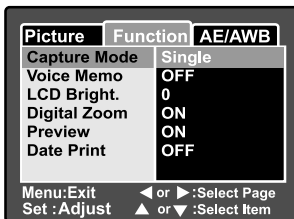

NOTE

- In the [Function] menu of [📷] mode, only the "LCD Bright." could be set.

Capture Mode

Capture mode is an option that allows you to capture a rapid sequence of images with one press of the shutter. There are two distinctly different aspects to this option - Continuous (burst) capture, and AEB (automatic exposure bracketing)

[Blank] Single: In this setting the feature is not invoked and the camera takes single-shots.

[📷] Continuous: In this setting, the camera will capture a sequential burst of three images (maximum) at an interval of 0.7 seconds (maximum rate.) The continuous burst mode is very useful for photographing objects in motion where it is difficult to determine the precise moment of capture. Afterwards, you may review the sequence of shots to select the best one.

[AEB] Auto Exp.: Auto-exposure bracketing is an effective technique when it is difficult to determine the precise exposure of a scene. Using AEB the camera will capture a sequential burst of three images at three different exposure settings. One shot will be at the level of exposure automatically determined by the camera, eV0. The two complementary shots will be underexposed (eV -0.67), and overexposed (eV +0.67) respectively. Afterwards, you may review the sequence of shots to select the best exposure.



NOTE

- For continuous (burst) photography, press and hold the shutter button until all three images have been captured. If the shutter button is released earlier, the burst will end at that point.

Voice Memo

A voice memo can be recorded for 30 seconds immediately following still image capture. This feature is also available during playback mode.

Refer to the sections in this manual titled “[**AE**] Auto Mode” and “Attaching Voice Memos” for further details.

ON: Enable voice memo.

OFF: Disable voice memo.

LCD Bright.

Select a brightness level for the LCD monitor. The LCD becomes brighter with the **▲** button and darker with the **▼** button. The adjustment range is from -5 to +5.

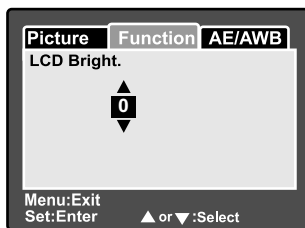

Digital Zoom

This enables or disables digital zoom.

ON: Enable digital zoom.

OFF: Disable digital zoom.

Preview

This sets whether or not to display the captured image on the screen immediately after the image is captured.

ON: Display when images are being recorded to the SD card.

OFF: Does not display.



NOTE

- A captured image is displayed on the LCD monitor for about two seconds. Pressing the shutter button during preview cancels the operation.
- When preview is set to off, the voice memo setting is also fixed to off.

Date Print

The date of recording can be printed directly on still images. This function must be activated before the image is captured.

ON: Imprints the date on still images when capturing images.

OFF: Does not imprint the date on the still images when capturing images.

Photography Menu (AE/AWB tab)

- Slide the mode switch to and set the mode dial to one of the photography modes.
- Press the **MENU** button, and select the [AE/AWB] menu with the **▶** button.
 - The [AE/AWB] tab of the photography menu is displayed.
- Select the desired [AE/AWB] option item with the **▲/▼** buttons, and press the **SET** button to enter its respective menu.
- Select the desired setting with the **▲/▼** buttons, and press the **SET** button.
- To exit from this menu, press the **MENU** button.

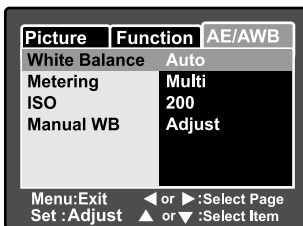

NOTE

- The [AE/AWB] menu is not available in the [**A**] mode.
- In the [] mode, the "Metering" and "ISO" cannot be set.

White Balance

This specifies the white balance settings to be used by the camera for particular lighting conditions.

- [Blank] Auto:** The camera will determine white balance automatically.
- [] Incandescent:** For photography under incandescent lighting.
- [] Fluorescent 1:** For photography under a daylight fluorescent tube with a bluish cast.
- [] Fluorescent 2:** For photography under a daylight white fluorescent tube with a reddish cast.
- [] Day Light:** Outdoor photography.
- [] Cloudy:** For photography under a cloudy sky.
- [] Manual:** For photography with a Manual WB.

Metering

This sets the exposure-metering method for calculating proper exposure.

- [] Multi:** The entire area of the screen is measured, and the exposure is calculated.
- [] Spot:** A very small portion of the center of the screen is measured, and the exposure is calculated.

ISO

This sets the light sensitivity for capturing images. When the sensitivity is raised (the ISO figure is increased), the camera sensitivity is enhanced for low-lighting, but your images will appear more pixilated (grainy).

50: Equivalent to ISO 50.

100: Equivalent to ISO 100.

200: High-sensitive photography equivalent to ISO 200.

Auto: The camera will determine ISO sensitivity automatically. (Auto ISO is available only in the [A], [P], [Q], [S] or [C] mode.)

Manual WB

This allows for manually setting the white balance. Manual WB is convenient when the white balance presets do not offer a good match to your specific lighting conditions.

Before selecting [Execute] select a white subject (such as a white paper) that will be used to set the white balance.

Cancel: Disable manual white balance.

Execute: Enable manual white balance.

Playback Menu

In the [▶] mode, you may adjust playback settings. These settings are not canceled even if the camera is turned off or the Auto Power Off function is activated.

1. Set the mode dial to [▶].
2. Press the **MENU** button.
 - The playback menu is displayed.
3. Select the desired option item with the ▲/▼ buttons, and press the **SET** button to enter its respective menu.
4. Select the desired setting with the ▲/▼ buttons, and press the **SET** button.
5. To exit from the playback menu, press the **MENU** button.



Slide Show

Automatic sequential play back of still images.

Refer to the section in this manual titled “**Slideshow Display**” for further details.

DPOF

Set the number of prints and date display in DPOF format to images that you want to print. (This function is available for still images only.) You can print images easily just by inserting the SD card to a DPOF-compatible printer or a print shop.

Refer to the section in this manual titled “**DPOF Settings**” for further details.

Protect

Protect an image to prevent accidental erasure.

Refer to the section in this manual titled “**Protecting Images**” for further details.

LCD Bright.

Adjust the brightness of the LCD monitor. This function does not adjust the brightness of your captured images.

Refer to the section in this manual titled “**LCD Bright.**” in **Photography Menu (Function tab)** for further details.

Setup Menu (Basic tab)

In the setup menus you may adjust your camera's operating environment. The settings will be retained after the power has been turned off or Auto Power Off is activated.

- Slide the mode switch to [📷] and set the mode dial to [SET].
 - The [Basic] tab of the set-up menu is displayed.
- Select the desired [Basic] option item with the ▲/▼ buttons, and press the **SET** button to enter its respective menu.
- Select the desired setting with the ▲/▼ buttons, and press the **SET** button.
- To exit from the set-up menu, change the mode dial setting.

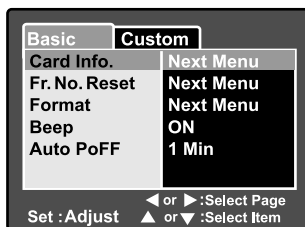

Card Info.

This will display the total capacity of your memory card as well as the remaining (unused) capacity. Note that the stated capacity may be less than the advertised (labeled) capacity of your SD memory card. This is attributable to the difference between binary (base 2) and engineering (base 10) methods of capacity calculation.

Fr. No. Reset

This creates a new folder on your memory card. From this point forward, newly captured images are stored in the newly created folder starting with image number 0001.

Cancel: Does not reset the file number.

Execute: Resets the file number and creates a new folder.

Format

This function reformats the SD card loaded in your camera and thereby erases all images as well as any other non-image data on the memory card. Even protected images are. An SD card cannot be formatted if it is write-protected. Refer to the section in this manual titled “**Formatting an SD Card**” for further details.

Beep

Enables or disables the sounds (beeps) associated with camera button functions.

ON: Enables sounds/beep tones.

OFF: Disables sounds/beep tones.

Auto PoFF

If no operation is performed for a specific period of time, the camera will automatically turn off. This feature is useful to reduce battery consumption.

- 1 Min.:** When the camera has not been operated, it turns the power off after 1 minute.
- 2 Min.:** When the camera has not been operated, it turns the power off after 2 minutes.
- 3 Min.:** When the camera has not been operated, it turns the power off after 3 minutes.



NOTE

- The auto power-off function is disabled during a slideshow or during PC connection.

Setup Menu (Custom tab)

- Slide the mode switch to [CAM] and set the mode dial to [SET].
- Select the [Custom] menu with the ► button.
 - The [Custom] tab of the set-up menu is displayed.
- Select the desired [Custom] option item with the ▲/▼ buttons, and press the **SET** button to enter its respective menu.
- Select the desired setting with the ▲/▼ buttons, and press the **SET** button.
- To exit from the set-up menu, change the mode dial setting.

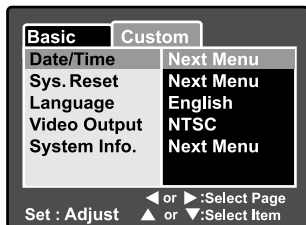

Date/Time

This sets the date and the time.

Refer to the section in this manual titled “**Setting the Date and Time**” for further details.

Sys. Reset

This returns all basic settings to the camera’s default settings. Note that the date and time setting will not be reset, however.

Cancel: Does not reset the camera to the factory default settings and the current settings are retained, unchanged.

Execute: Resets the camera to its original factory default settings.

Language

This sets the language that is displayed on the LCD monitor.

Refer to the section in this manual titled “**Choosing the OSD Language**” for further details.

Video Output

This sets video output standard of the camera so you may connect your camera to video equipment.

NTSC: NTSC broadcast standard.

PAL: PAL broadcast standard.

System Info.

This displays the firmware version of the camera.

TRANSFERRING RECORDED IMAGES AND VIDEOS TO YOUR COMPUTER

To transfer images/video clips from the camera to your computer, follow these steps:

Step 1: Installing the USB driver (Windows 98 and Mac OS 8.6 users only)

Step 2: Connecting the camera to your computer

Step 3: Downloading images and video files

System Requirements (Windows)

- Pentium 166 MHz or higher
- Windows 98/98SE/Me/2000/XP
- 128MB RAM
- 128MB hard disk space
- CD-ROM drive
- Available USB port

System Requirements (Macintosh)

- PowerPC G3/G4
- OS 8.6 or later
- 128MB RAM
- 128MB hard disk space
- CD-ROM drive
- Available USB port

Step 1: Installing the USB Driver

Windows 98 computers

The USB driver on the CD-ROM is exclusively for Windows 98 computers. Installing the USB driver on computers running Windows 2000/ME/XP is not necessary.

1. Insert the CD-ROM that came with the camera into your CD-ROM drive. The welcome screen appears.
2. Click **"INSTALL USB DRIVER"**. Follow the on-screen instructions to complete the installation. After the USB driver has been installed, restart your computer.



Macintosh OS 8.6 computers

Mac OS 8.6 users must install a USB driver. For Mac OS 9.0 or higher, the computer will automatically recognize the camera and load its own USB drivers.

1. Insert the CD-ROM that came with the camera into the CD-ROM drive.
2. Select and double-click **"Digital Camera Driver Installer"**.
3. Select **"Install Location"** and click **"Install"**.
4. Follow the on-screen instructions to complete the installation and restart your computer.

Step 2: Connecting the Camera to Your Computer

1. Connect one end of the USB cable to the USB terminal of the camera.
2. Connect the other end of the USB cable to an available USB port on your computer.
3. Turn on your camera.
4. The [USB] screen appears. Select [PC] with the ▲/▼ buttons, and press the **SET** button.
5. From the Windows desktop, double click on "My Computer".
6. Look for a new "Removable disk" icon. This "Removable disk" is actually the memory card in your camera. Typically, the camera will be assigned drive letter "e" or higher.
7. Double click on the removable disk and locate the DCIM folder.
8. Double click on the DCIM folder to open it to find more folders.
 - Your recorded images and video clips will be inside these folders.
 - Copy & Paste or Drag-N-Drop image and video files to a folder on your computer.

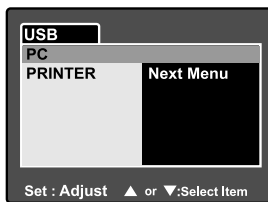
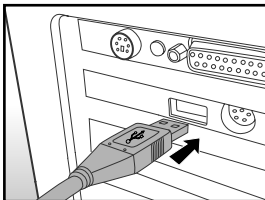
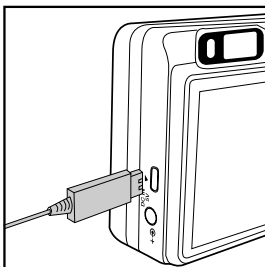

Mac users: Double-click the "untitled" or "unlabeled" disk drive icon on our desktop. iPhoto may automatically launch.



NOTE

- The data saved to the SD card may be damaged if the power to the camera is cut off during image transfer. We recommend that you use the AC power adapter when connecting the camera to the PC.

Step 3: Downloading Images and Video Files

When the camera is turned on and connected to your computer, it is considered to be a disk drive, just like a floppy disk or CD. You can download (transfer) images by copying them from the “Removable disk” (“untitled” or “unlabeled” disk on a Macintosh) to your computer hard drive.

Windows

Open the “removable disk” and subsequent folders by double clicking on them. Your images are inside these folder(s). Select the images that you want, and then choose “Copy” from the “Edit” menu. Open the destination location (folder) and choose “Paste” from the “Edit” menu. You may also drag and drop image files from the camera to a desired location.

Macintosh

Open the “untitled” disk icon, and the destination location on your hard disk. Drag and drop from the camera to the desired destination. Do not open the battery cover during USB cable connection.



NOTE

- Memory card users may prefer to use a memory card reader (highly recommended).
- A video playback application is not included with the package. Make sure that a video playback application has been installed in your computer.

CONNECTING THE CAMERA DIRECTLY TO THE PRINTER FOR PRINTING IMAGES (PICTBRIDGE FUNCTION)

If a printer that support PictBridge is available, images can be printed by connecting the camera directly to the PictBridge-compatible printer without using a computer.

1. Connect one end of the USB cable to your camera.
2. Connect the other end of the USB cable to the USB port on the printer.
3. Turn on your camera.

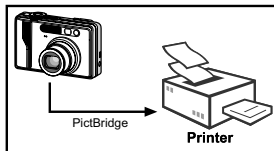

4. The [USB] screen is displayed. Select [PRINTER] with the ▲/▼ buttons, and press the **SET** button.
5. Select the item you want to configure with the ▲/▼ buttons, and press the **SET** button.

[Images]: Select whether you want to print specific image or all images. You may also select printing number for specific image.

[Date Print]: According to the printer type, select whether you want to print the image with date imprint or not.

[Paper Size]: Select the desired paper size according to the printer type.

[Layout]: Select the desired printing layout according to the printer type.

[Print]: After all settings is configured, select this item to start printing.

6. If you select [Images] in the previous step, the figure shown on the right hand side will appear. Select [Single] or [All] with the ▲/▼ buttons, and press the **SET** button.

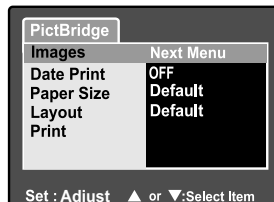
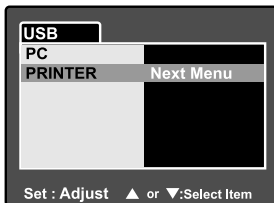

7. If you select [Single] in the previous step, the figure shown on the right hand side will appear.

- Select the image that you want to print with the ◀/▶ buttons.
- Select the printing number (up to 99) with the ▲/▼ buttons.
- After selecting the desired image and printing number, press the **SET** button to confirm.

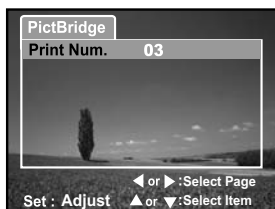

8. Select [Exit] with the ▲/▼ buttons, and press the **SET** button.

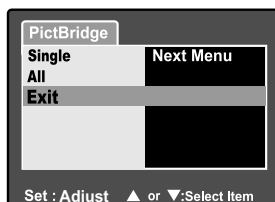

9. Select [Print] with the ▲/▼ buttons, and press the **SET** button to start printing.

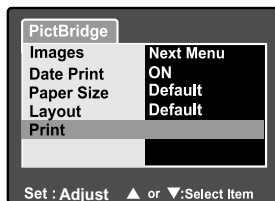

10. The printing starts and the figure shown on the right hand side appears.

- The [Complete] screen will be displayed temporarily, reminding you that the printing procedure is finished.
- If a print error is detected, the [Print Error] screen will be displayed.

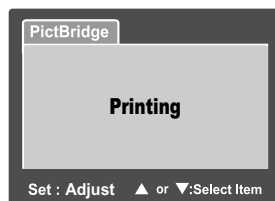

- The image printing may be failed if the power to the camera is accidentally cut off. We recommend that you use the AC power adapter when connecting the camera to the printer.

INSTALLING PHOTO EXPLORER

Ulead® Photo Explorer provides a simple and efficient way to transfer, browse, modify and distribute digital media. Acquire photos, video or sound clips from various digital device types and easily browse or add personal descriptions; make timely modifications; or distribute the media through the medium of your choice: E-mail, Print, Slideshow Presentations. It is an indispensable all-in-one tool for owners of digital cameras, WebCams, DV camcorders, scanners, or anyone who strives to effectively organize a large collection of digital media.

To install Photo Explorer:

1. Insert the CD-ROM that came with the camera into your CD-ROM drive. The welcome screen appears.
2. Click **"INSTALL Photo Explorer 8.0"**. Follow the on-screen instructions to complete the installation.



NOTE

- For more information about the operation of Photo Explorer application software, refer to its respective help documentation.
- For Windows 2000/XP users, please make sure to install and use the Photo Explorer in "Administrator" mode.
- Photo Explorer is not supported on the Mac. iPhoto or iPhoto2 is recommended.

INSTALLING PHOTO EXPRESS

Ulead® Photo Express is complete photo project software for digital images. The step-by-step workflow, visual program interface, and in-program help assist users in creating exciting photo projects. Acquire digital photos effortlessly from digital cameras or scanners. Organize them conveniently with the Visual Browse mode. Use hundreds of ready-to-use templates such as albums, cards, posters, slideshows, and more. Edit and enhance images with photo editing tools, photographic filters, and special effects. Embellish projects by adding creative design elements such as frames, callouts, and stamp objects. Share results with family and friends via e-mail and multiple print options.

To install Photo Express:

1. Insert the CD-ROM that came with the camera into your CD-ROM drive. The welcome screen appears.
2. Click **"INSTALL Photo Express 5.0"**. Follow the on-screen instructions to complete the installation.



NOTE

- For more information about the operation of Photo Express application software, refer to its respective help documentation.
- For Windows 2000/XP users, please make sure to install and use the Photo Express in "Administrator" mode.
- Photo Express is not supported on the Mac.

CONNECTING THE CAMERA TO OTHER DEVICES

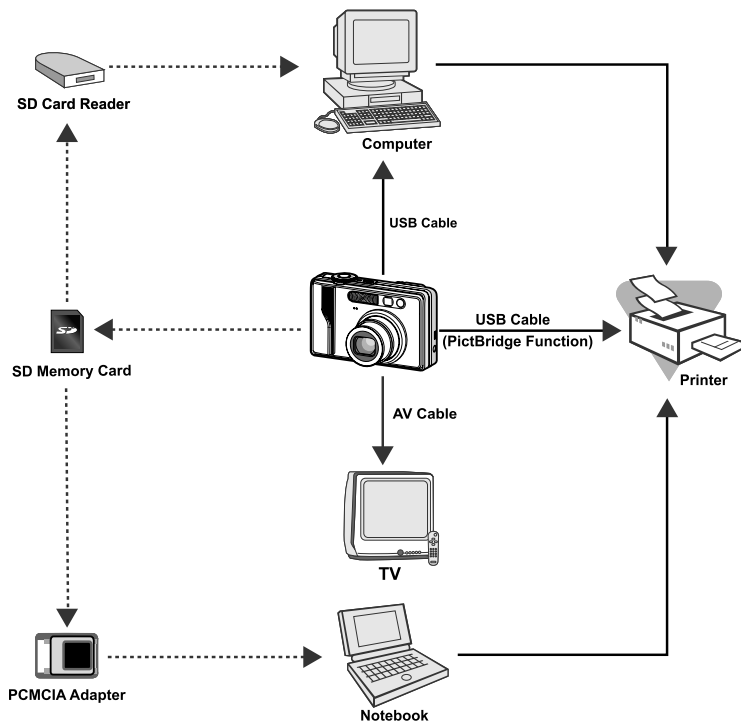

CAMERA SPECIFICATIONS

Item	Description
Image sensor	8.1 Mega pixels CCD sensor
Image resolution	<Still image> 3264 x 2448, 2560 x 1920, 1600 x 1200, 640 x 480 < Video clip> 640 x 480
LCD monitor	2.5" LTPS TFT color LCD
Viewfinder	Real image optical zoom viewfinder
Image quality	Fine/Standard/Economy/TIFF
Recording media	External memory: Supports SD card (optional, up to 1GB)
Compression format	JPEG compliant
Image file format	JPEG (EXIF 2.2), DCF, DPOF, AVI
Lens	3x optical zoom lens F-no.: 2.8 (Wide)/4.8 (Tele) Focal length: 7.5 mm ~ 22.5 mm (equivalent to 36 mm - 108 mm on a 35 mm camera)
Range of focus	Wide: Approx. 5 cm to infinity (in Macro mode) Tele: Approx. 30 cm to infinity (in Macro mode) Normal: Approx. 50 cm to infinity
Shutter speed	1/2 -1/1500 sec.
Image capturing	Single/3 images burst/AEB with 3 images at -0.67, 0, +0.67EV
Digital zoom	5.1x (Still-image capture mode) 2x and 4x enlargement (Still-image playback mode)
Metering system	Multi/Spot
Exposure compensation	-2EV ~ +2EV (in 0.3EV increments)
White balance	Auto/Incandescent/Fluorescent 1/Fluorescent 2/ Day Light/Cloudy/Manual
Flash modes	Automatic/Red-eye Reduction/Forced Flash/ Flash Off
Flash effective range	0.5 m -2.7 m

Item	Description
ISO sensitivity	Equivalent to ISO 50/100/200/Auto
Self-timer	10 sec./2 sec./10+2 sec.
Video standards	NTSC/PAL
Interface	DC IN 5V terminal A/V OUT terminal USB terminal (USB 1.1, Full speed)
Power supply	Rechargeable Lithium-ion battery (3.7V) AC power adapter (5V/3A)
Dimension (WxHxD)	Approx. 91 x 57 x 27mm (without protruding parts)
Weight	Approx. 150 g (without the battery & SD card)

* Design and specifications are subject to change without notice.

TROUBLESHOOTING

Refer to the symptoms and measures listed below before sending the camera for repairs. If the problem persists, contact your local reseller or service center.

Power Supply

Symptom	Cause	Measure
The power does not come on.	The battery is not loaded.	Load the battery correctly.
	The battery is exhausted.	Recharge or use the AC power adapter.
	The AC power adaptor is not connected correctly.	Reconnect it properly.
The power cuts out during use.	The camera was left unattended and unused, so the auto power off cuts it off.	Turn the power back on.
	The battery is exhausted.	Recharge or use the AC power adapter.
The power does not go off.	Camera malfunction.	Reload the battery. If using the AC power adapter, reconnect it.
The battery runs out quickly.	It is being used in extreme low temperature.	
	Many shots are being captured in dark places inside, requiring flash.	
	The battery is not fully charged. The battery is not used for an extended period of time after charged.	Fully charge the battery and discharge it for at least one complete cycle before use to maximize its performance and lifetime.
The battery or camera feels warm.	Long period of continuous use of the camera or the flash.	

Shooting

Symptom	Cause	Measure
Even if I press the shutter button, the camera does not shoot.	The battery is running low.	Recharge or use the AC power adapter.
	The power is not on.	Turn the power on.
	The camera is not in shooting mode.	Slide the mode switch to shooting mode.
	The shutter button is not pressed all the way.	Press the shutter button all the way.
	The memory card does not have any free space.	Load a new card, or delete unwanted files.
	End of memory card life.	Load a new memory card.
	The flash is recharging.	Wait until the status LED off.
	The memory card is unrecognized by the camera.	Format the memory card in this camera before its first use or when it was used other than this camera.
Images do not appear on the LCD monitor.	The auto power off function is activated.	Turn the power on again.
	The power is not on.	Turn the power on.
	The LCD monitor is dark.	Adjust the brightness of the LCD monitor in the photography or playback menu.
Although it is set to Auto Focus, it does not focus.	The LCD monitor is not on.	Press the O button and switch display.
	The lens or Self-timer LED is dirty.	Wipe clean with a soft, dry cloth or lens paper.
	The distance to the subject is smaller than the effective range.	Get your subject within the effective focus range.

Symptom	Cause	Measure
The flash does not fire. The flash cannot recharge.	The camera is set to /▲/ mode.	Switch the camera mode to someone other than one of those.
	The flash is set to flash off.	Set the flash to something other than flash off mode.
Even though the flash fired, the image is dark.	The distance to the subject is greater than flash effective range.	Get closer to your subject and shoot.
The image is too dark.	The image was captured in a dark place while set to flash off.	Set the flash to something other than flash off mode.
	It is under-exposed.	Set the exposure compensation to a larger value.
The image is too bright.	It is over-exposed.	Set the exposure compensation to a smaller value.
The image lacks natural color.	The image was captured in conditions that are hard for Auto White Balance to adjust to.	Add a white object to the composition.

Playback

Symptom	Cause	Measure
Cannot playback`	It is not set to playback mode.	Slide the mode switch to playback mode.
The contents of memory card cannot be replayed.	You played back a memory card that was not formatted by this device.	Loaded a card that was formatted and stored on by this device.
Files cannot be deleted.	The file is protected.	Cancel protection.
	You played back a memory card that was not formatted by this device.	Loaded a card that was formatted and stored on by this device.
Cannot format a memory card.	The memory card is write-protected.	Remove the write-protection.
	End of memory card life.	Load a new memory card.
The playback image is dark though I used the flash.	The LCD monitor is too dark.	Adjust the brightness of LCD monitor.

Other Problems

Symptom	Cause	Measure
Cannot load the memory card.	The card is facing the wrong way.	Load correctly.
Even when the camera's buttons are pressed, it does not operate.	The battery is running low.	Recharge or use the AC power adapter.
	Camera malfunction.	Turn the power off and remove the battery once, and try again.
The date and time is wrong.	The correct date and time is not set.	Set the correct date and time.
The date set has disappeared.	The battery is removed with the power still on.	Set the date and time again.

About connecting to your computer/software

Symptom	Cause	Measure
Cannot download images.	The free space on the hard disk in your computer may be insufficient.	Check whether the hard disk has a space for running Windows, and if the drive for loading image files has a capacity at least that of the memory card inserted in the camera.
	No power supply.	Recharge the battery or use the AC power adapter or turn the power on.
	The USB driver is not installed (for Windows 98/98SE and MAC OS 8.6).	Install USB driver.
Cannot access TIFF file format.	Your application is not supported TIFF file format captured by this camera.	Only use the supplied application that bundled with CD-ROM.